

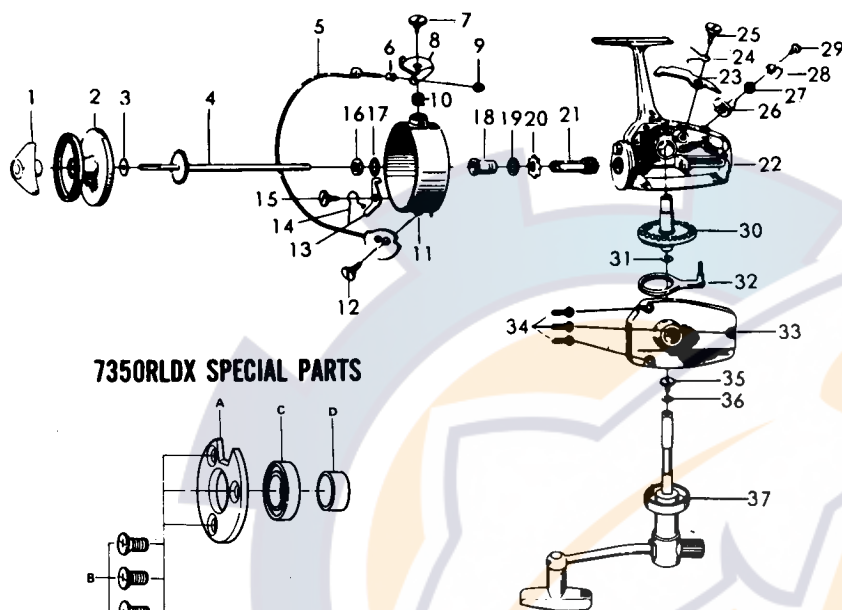

SPINNING REEL **7350RL**  
**7350RLDX**

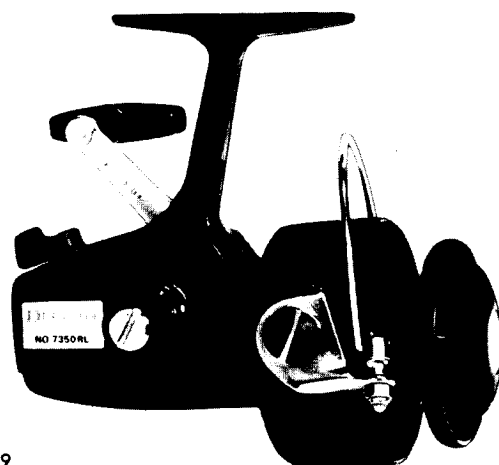

7350RLDX SPECIAL PARTS			Price
A	66311501 (63115)	Ball bearing retaining washer	\$.50
B	63512201 (35122)	Ball bearing ret. washer screw	.50
C	66310041 (631101)	Ball bearing	3.50
D	65003001 (5030)	Pinion collar B	.50

LINE CAPACITY: 250 YDS., 12 LB. TEST

Key No.	Parts No.	Parts Name	Price	Key No.	Parts No.	Parts Name	Price	Key No.	Parts No.	Parts Name	Price
1	60034423 (A00344)	Drag knob	\$1.20	15	63611511 (36115a)	Bail kick lever screw	\$.50	28	65403711 (5437)	Anti-reverse lever	\$.50
2	60034731 (A00347)	Spool assembly	3.60	16	63405842 (3458)	Rotor nut	.50	29	63501931 (3519a)	Anti-reverse lever screw	.50
3	63714412 (37144-2)	Spool washer	.50	17	61601611 (1616a)	Rotor washer	.50	30	64110851 (41108a)	Drive gear	2.25
4	60034801 (A00348)	Main shaft	1.20	18	65002431 (5024)	Pinion collar A	.50	31	63712820 (37128-4)	Drive gear washer	.50
5	60028832	Bail	2.00	19	65002301 (5023)	Pinion collar B	.50	32	60075311	Oscillating slider	.60
6	62501901 (2519)	Line roller	.50	20	62801321 (2813)	Ratchet	.50	33	60608211 (0682)	Body cover	2.00
7	63616401 (36164)	Arm lever screw	.50	21	64007741 (4077)	Pinion	1.25	34	63513701 (35137)	Body cover screw	.50
8	62303911 (2339a)	Arm lever	.50	22	60064504 (A00645)	Body	4.00	35	63513631 (35136)	Handle screw	.50
9	63408201 (3482)	Bail nut	.50	23	61104011 (1140)	Anti-reverse claw	.50	36	63719521 (37195)	Handle washer	.50
10	61409221 (1492a)	Bail spring	.50	24	61413011 (14130)	Anti-reverse claw spring	.50	37	60073661	Handle	4.50
11	60064641 (A00646)	Rotor	3.25	25	63611511 (36115a)	Anti-reverse claw screw	.50	(19, 7350RL only) For 7350RLDX only			
12	63616501 (36165)	Bail holder screw	.50	26	64602811 (4628)	Anti-reverse cam	.50				18
13	65706611 (5731a)	Bail kick lever	.50	27	61501751 (1517b)	Anti-reverse lever washer	.50	22	60065003 (A00650-2)	Body	4.00
14	61405031 (1450c)	Bail kick lever spring	.50								

ALWAYS SPECIFY MODEL NO., PART NAME & PARTS NO. WHEN ORDERING PARTS  
PLEASE ENCLOSE CORRECT AMOUNT FOR PART'S PRICE WHEN ORDERING